

● 3PKT 15 90 DEGREE

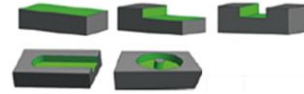

90 DEGREE POSITIVE FACE MILLING INSERT WITH FOUR CUTTING EDGES

True 90° milling solution

High positive axial rake angle for low cutting force and improved productivity

Finer pitch cutters maximize productivity

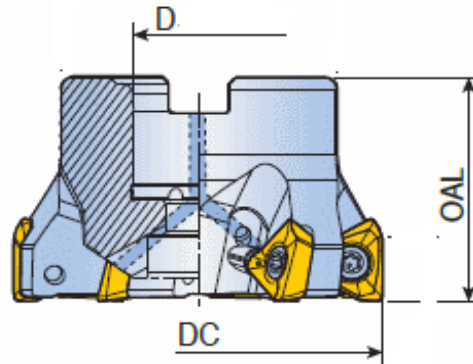

● Face Mill Type Cutter

ITEM DESCRIPTION	Dimension (mm)				insert	Spare Parts	
	DC	D	OAL	Z		SCREW	KEY
FMC50R-22-4T-3PKT15	50	22	40	4	3PKT 15	M4	T15
FMC63R-22-5T-3PKT15	63	22	40	5	3PKT 15	M4	T15
FMC80R-27-6T-3PKT15	80	27	50	7	3PKT 15	M4	T15
FM100R-34-7T-3PKT15	100	32	50	8	3PKT 15	M4	T15
FMC125R-40-8T-3PKT15	125	40	60	10	3PKT 15	M4	T15

● Insert

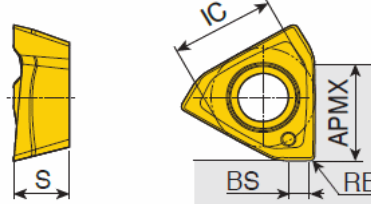

ITEM CODE	Dimension (mm)				Grade		
	IC	RE	S	APMX	AS9030	AS1007	AS7020
3PKT 1505	10.7	0.8	5	11	●	●	●

3PKT 1505□□

Recommended Cutting Conditions

ISO	Work Material	Grade	Ap (Max)	Cutting Speed Vc (m/min)	Feed Rate fz (mm/t)
P	Steel (Carbon,Alloy,Mold)	AS9030	1	110-250	0.15-0.4
		AS1007			
		AS7020			
M	Staniless Steel Austenite,Ferrite,Martensite	AS9030	1	60-150	0.1-0.3
		AS1007			
		AS7020			
K	Cast Iron (Grey,Nodular,Ductile)	AS9030	1	100-250	0.15-1
		AS1007			
		AS7020			
S	High Tempeature Alloys (Ti,Ee,Ni & Co Based)	AS9030	1	40-80	0.06-0.2
		AS1007			
		AS7020			
H	Hardened Steel	AS7020	1	30-80	0.6-0.2