

● SDMT 12 90 DEGREE

90DEGREE POSITIVE FACE MILLING INSERT WITH FOUR CUTTING EDGES

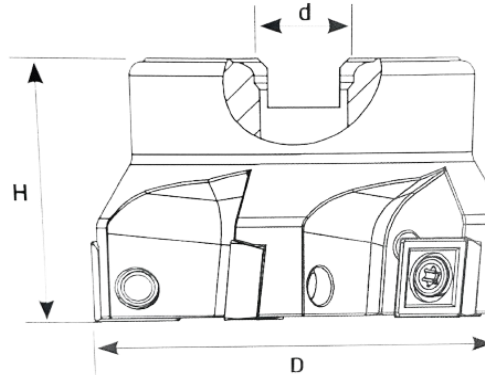
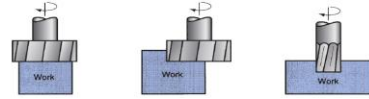

● Face Mill Type Cutter

ITEM DESCRIPTION	Dimension (mm)				insert	Spare Parts	
	D	Z	H	d		SCREW	KEY
FMC50R-22-4T-SDMT12	50	4	40	22	SDMT 1204	M3.5	T15
FMC63R-22-5T-SDMT12	63	5	40	22	SDMT 1204	M3.5	T15
FMC80R-27-6T-SDMT12	80	6	50	27	SDMT 1204	M3.5	T15
FM100R-34-7T-SDMT12	100	8	50	32	SDMT 1204	M3.5	T15
FMC125R-40-8T-SDMT12	125	8	63	40	SDMT 1204	M3.5	T15
FMC160R-40-10T-SDMT12	160	10	63	40	SDMT 1204	M3.5	T15
FMC200R-60-12T-SDMT12	200	12	63	60	SDMT 1204	M3.5	T15

● Insert

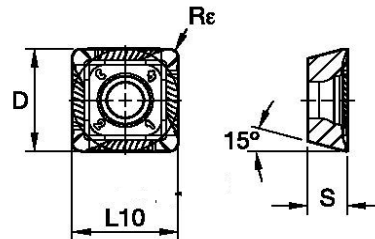

ITEM CODE	Dimension (mm)				Grade		
	D	L10	S	R	AS9030	AS1007	AS7020
SDMT 120408	12.7	12.7	4.77	0.8	●	●	●
SDMT 120412	12.7	12.7	4.77	1.2	●	●	●

SDMT 1204□□

Recommended Cutting Conditions

ISO	Work Material	Grade	Ap (Max)	Cutting Speed Vc (m/min)	Feed Rate fz (mm/t)
P	Steel (Carbon,Alloy,Mold)	AS9030	1	110-250	0.15-0.4
		AS1007			
		AS7020			
M	Staniless Steel Austenite,Ferrite,Martensite	AS9030	1	60-150	0.1-0.3
		AS1007			
		AS7020			
K	Cast Iron (Grey,Nodular,Ductile)	AS9030	1	100-250	0.15-1
		AS1007			
		AS7020			
S	High Tempeature Alloys (Ti,Ee,Ni & Co Based)	AS9030	1	40-80	0.06-0.2
		AS1007			
		AS7020			
H	Hardened Steel	AS7020	1	30-80	0.6-0.2