

● SEKT 12 FACE MILL

**45 DEGREE LEAD ANGLE INSERT 4 CUTTING
CORNER INSERT SUITABLE FOR FACE MILLING**

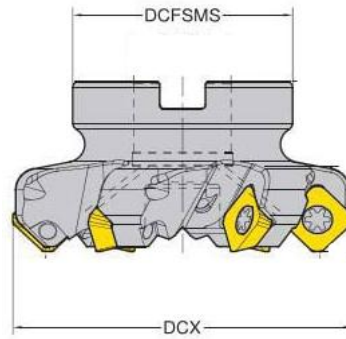

● SHELL MILL CUTTER

ITEM DESCRIPTION	DCX	DC	Z	insert	SCREW
SEKT12-50-22-4T	50	22	4	SEKT12	M3.5*10
SEKT12-63-27-6T	63	27	6	SEKT12	M3.5*10
SEKT12-80-27-8T	80	27	8	SEKT12	M3.5*10
SEKT12-100-32-10T	100	32	10	SEKT12	M3.5*10
SEKT12-125-40-12T	125	40	12	SEKT12	M3.5*10

● Insert

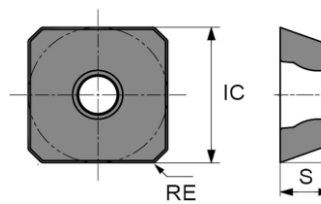

ITEM DESCRIPTION	IC	R	S	AS9030	AS1007	AL10
SEKT 1204 FTN	12	-	4	●	●	●

SEKT 1204□□

Recommended Cutting Conditions

ISO	Work Material	Grade	Ap (Max)	Cutting Speed Vc (m/min)	Feed Rate fz (mm/t)
P	Steel (Carbon,Alloy,Mold)	AS9030	1	110-250	0.15-0.4
		AS1007			
		AS80K			
M	Staniless Steel Austenite,Ferrite,Martensite	AS9030	1	60-150	0.1-0.3
		AS1007			
		AS80K			
K	Cast Iron (Grey,Nodular,Ductile)	AS9030	1	100-250	0.15-1
		AS1007			
		AS80K			
S	High Tempeature Alloys (Ti,Ee,Ni & Co Based)	AS9030	1	40-80	0.06-0.2
		AS1007			
		AS80K			
H	Hardened Steel	AS1007	1	30-80	0.6-0.2